

2-1 HOW TO USE THIS MANUAL

2001 F53

The purpose of this manual is to show electrical circuits in a clear and simple fashion to make troubleshooting easier. **NOTES, CAUTIONS** and **WARNINGS** contain important information.

- **NOTES** describe how switches and other components operate to help complete a particular procedure.
- **CAUTIONS** provide information that could prevent making an error that may damage the vehicle.
- **WARNINGS** provide information to prevent personal injury.

The **WARNINGS** list on page 2-2 contains general warnings to follow when servicing a vehicle.

Components that work together are shown together. All electrical components used in a specific system are shown on one diagram. The circuit breaker or fuse is shown at the top of the page. All wires, connectors, components and splices are shown in the flow of current to ground at the bottom of the page. If a component is used in several different systems, it is shown in several places. For example, the Main Light Switch is electrically a part of many systems and is repeated on many pages.

In some cases, a component may seem (by its name) to belong to a system where it has no electrical connection. For example, Radio Illumination is electrically part of Instrument Illumination, but because it has no electrical connection to the Radio system, it is not shown on the Radio diagram.

Schematic pages contain references to full-view illustrations and description notes for various components. The references are reverse-text blocks located next to each component and connector and refer the user to the appropriate illustration page and zone. The description notes describe the operation of the component.

Schematic pages contain circuit voltages to help simplify troubleshooting hints. 12V is used to imply battery voltage on a component connector terminal, and 0V is used to show that there should be continuity to ground on that particular terminal. Conditional voltages such as “12V with the ignition switch in RUN” will also be provided. Troubleshooting hints that can’t be simplified with circuit voltages will be shown at the end of each cell.

Component connector face information specific to a certain cell is found at the end of that cell. A Connector Face Reference List is provided to locate connector faces that are shown in different cells. Component connectors with five or more terminals are illustrated and are accompanied by a pinout chart that lists the function of all circuitry associated with that component.

“**GROUND**” (Cell 10) contains ground circuitry shown in complete detail. This information is useful for checking interconnections of the ground circuits of different systems.

“**POWER DISTRIBUTION**” (Cell 13) contains power distribution circuitry shown in complete detail. This section displays how the various fuses are powered and, in turn, how each system is powered.

“**COMPONENT TESTING**” (Cell 149) contains testing procedures for various switches. This information includes schematics, component terminal locations and step-by-step procedures.

“**IN-LINE CONNECTOR FACES**” (Cell 150) contains illustrations of all the in-line connectors that have 6 or more terminals. The terminals have pin numbers assigned to them.

“**COMPONENT LOCATION VIEWS**” (Cell 151) contains full-view illustrations which show the location of components and connectors in the vehicle.

The “**LOCATION INDEX**” (Cell 152) provides the base part numbers, locations, connector face references and illustration references for all components, connectors, splices and grounds.

HELPFUL REMINDERS

Before using the wiring diagrams for troubleshooting, refer to these HELPFUL REMINDERS:

1. The abbreviation T/O, for take out, used in the Location Index (Cell 152), refers to the point at which a group of wires branch off the harness trunk. Refer to the wiring harness illustration.

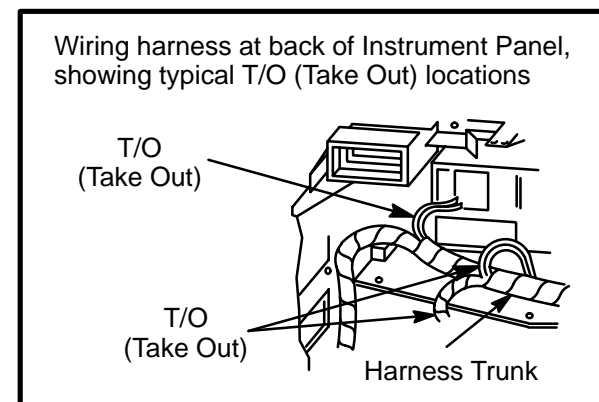

2. If a connector serves the same purpose in two separate versions (e.g., Automatic/Manual), but is physically different, *two* connector numbers are used. However, if a connector serves the same purpose in two separate versions (e.g., Automatic/Manual) and is physically the same, but the wire colors are different, only *one* connector number is used. If the same physical connector is used more than once, then more than *one* connector number is used.

3. Wiring schematics provide a picture of how and under what conditions the circuit is powered, of the current path to circuit components, and of how a circuit is grounded. Each circuit component is named (underlined titles). Wire and connector colors are listed as follows (standard Ford color abbreviations are used):

COLOR ABBREVIATIONS

BU	Blue	NA	Natural
BK	Black	OG	Orange
BN	Brown	PK	Pink
DB	Dark Blue	VT	Purple
DG	Dark Green	RD	Red
GN	Green	SR	Silver
GY	Gray	TN	Tan
LB	Light Blue	WH	White
LG	Light Green	YE	Yellow

Note: Whenever a wire is labeled with two colors, the first color listed is the basic color of the wire, and the second color listed is the stripe marking of the wire.

4. When reporting Vehicle Repair Location Codes to Ford Customer Service Division, refer to Cell 160 (beginning on page 160-1). Note: Do *not* use the illustrations in Cell 151 (beginning on page 151-1) for reporting Vehicle Repair Location Codes.

5. WARNINGS

- *Always wear safety glasses for eye protection.*
- *Use safety stands whenever a procedure requires being under a vehicle.*
- *Be sure that the **Ignition Switch** is always in the OFF position, unless otherwise required by the procedure.*
- *Set the parking brake when working on any vehicle. An automatic transmission should be in PARK. A manual transmission should be in NEUTRAL.*
- *Operate the engine only in a well-ventilated area to avoid danger of carbon monoxide.*
- *Keep away from moving parts, especially the fan and belts, when the engine is running.*
- *To prevent serious burns, avoid contact with hot metal parts such as the radiator, exhaust manifold, tail pipe, catalytic converter and muffler.*
- *Do not allow flame or sparks near the battery. Gases are always present in and around the battery cell. An explosion could occur.*
- *Do not smoke when working on a vehicle.*
- *To avoid injury, always remove rings, watches, loose hanging jewelry and avoid wearing loose clothing.*

HOW TO FIND ELECTRICAL CONCERNS

TROUBLESHOOTING STEPS

These six steps present an orderly method of troubleshooting.

Step 1. Verify the concern.

- Operate the complete system to check the accuracy and completeness of the customer's complaint.

Step 2. Narrow the concern.

- Using the wiring diagrams, narrow down the possible causes and locations of the concern to pinpoint the exact cause.
- Read the description notes at the components and study the wiring schematic. You should then know enough about the circuit operation to determine where to check for the trouble. Further information can be found by referring to the Service Manual pages listed in the box at the top of the page.

Step 3. Test the suspected cause.

- Use electrical test procedures to find the specific cause of the symptoms.
- The component location reference bars and the pictures will help you find components. The Location Index (at the end of the manual) gives component location information for connectors, diodes, resistors, splices and grounds.

Step 4. Verify the cause.

- Confirm that you have found the correct cause by connecting jumper wires and/or temporarily installing a known good component and operating the circuit.

Step 5. Make the repair.

- Repair or replace the inoperative component.

Step 6. Verify the repair.

- Operate the system as in Step 1 and check that your repair has removed all symptoms without creating any new symptoms.

2-3 HOW TO USE THIS MANUAL

2001 F53

Some engine circuits may need special test equipment and special procedures. See the *Workshop Manual* and other service books for details. You will find the circuits in this manual to be helpful with those special test procedures.

TROUBLESHOOTING TOOLS

JUMPER WIRE

This is a test lead used to connect two points of a circuit. A Jumper Wire can bypass an open to complete a circuit.

WARNING

Never use a jumper wire across loads (motors, etc.) connected between hot and ground. This direct battery short may cause injury or fire.

VOLTMETER

A DC Voltmeter measures circuit voltage. Connect negative (- or black) lead to ground, and positive (+ or red) lead to voltage measuring point.

OHMMETER

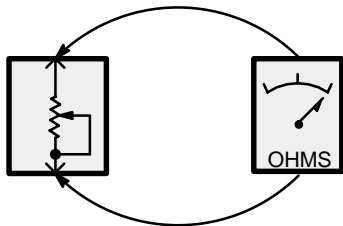

Figure 1 – Resistance Check

An Ohmmeter shows the resistance between two connected points (Figure 1).

TEST LAMP

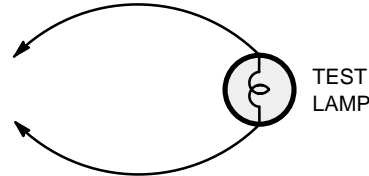

Figure 2 – Test Lamp

A Test Light is a 12-volt bulb with two test leads (Figure 2).

Uses: Voltage Check, Short Check.

SELF-POWERED TEST LAMP

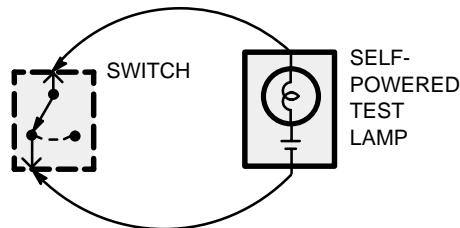

Figure 3 – Continuity Check

The Self-Powered Test Lamp is a bulb, battery and set of test leads wired in series (Figure 3). When connected to two points of a continuous circuit, the bulb glows.

Uses: Continuity Check, Ground Check.

CAUTION

When using a self-powered test lamp or ohmmeter, be sure power is off in circuit during testing. Hot circuits can cause equipment damage and false readings.

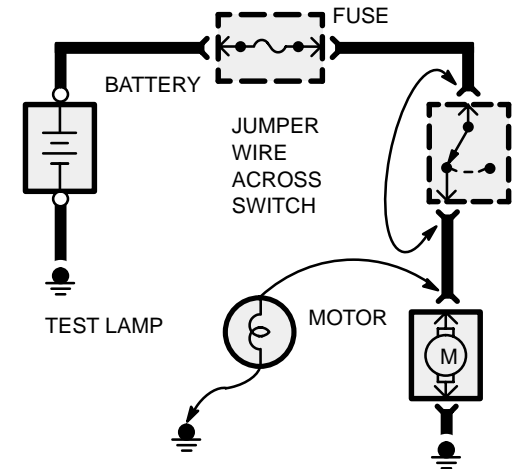

Figure 4 – Switch Circuit Check and Voltage Check

In an inoperative circuit with a switch in series with the load, jumper the terminals of the switch to power the load. If jumpering the terminals powers the circuit, the switch is inoperative (Figure 4).

CONTINUITY CHECK (Locating open circuits)

Connect one lead of Self-Powered Test Lamp or Ohmmeter to each end of circuit (Figure 3). Lamp will glow if circuit is closed. Switches and fuses can be checked in the same way.

VOLTAGE CHECK

Connect one lead of test lamp to a known good ground or the negative (-) battery terminal. Test for voltage by touching the other lead to the test point. Bulb goes on when the test point has voltage (Figure 4).

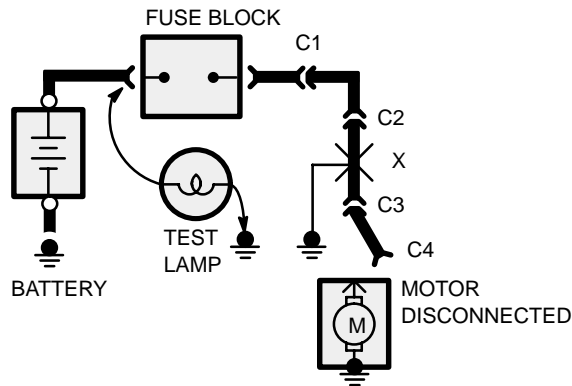

Figure 5 – Short Check

A fuse that repeatedly blows is usually caused by a short to ground. It's important to be able to locate such a short quickly (Figure 5).

1. Turn off everything powered through the fuse.
2. Disconnect other loads powered through the fuse:
 - Motors: disconnect motor connector (Connector C4 in Figure 5).
 - Lights: remove bulbs.
3. Turn Ignition Switch to RUN (if necessary) to power fuse.

4. Connect one Test Lamp lead to hot end of blown fuse. Connect other lead to ground. Bulb should glow, showing power to fuse. *(This step is just a check to be sure you have power to the circuit.)*
5. Disconnect the test lamp lead that is connected to ground, and reconnect it to the load side of the fuse at the connector of the disconnected component. (In Figure 5, connect the test lamp lead to connector C4.)

- If the Test Lamp is off, the short is in the disconnected component.
- If the Test Lamp goes on, the short is in the wiring. You must find the short by disconnecting the circuit connectors, one at a time, until the Test Lamp goes out. For example, in Figure 5 with a ground at X, the bulb goes out when C1 or C2 is disconnected, but not after disconnecting C3. This means the short is between C2 and C3.

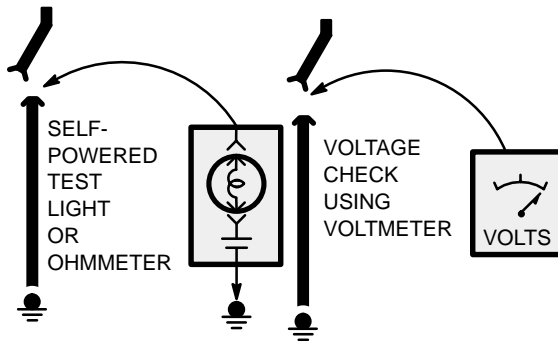

Figure 6 – Ground Check

Turn on power to the circuit. Perform a Voltage Check between the suspected inoperative ground and the frame. Any indicated voltage means that the ground is inoperative (Figure 6).

Turn off power to the circuit. Connect one lead of a Self-Powered Test Lamp or Ohmmeter to the wire in question and the other lead to a known ground. If the bulb glows, the circuit ground is OK (Figure 6).

The circuit schematics in this manual make it easy to identify common points in circuits. This knowledge can help narrow the concern to a specific area. For example, if several circuits fail at the same time, check for a common power or ground connection (see *Power Distribution* or *Grounds*). If part of a circuit fails, check the connections between the part that works and the part that doesn't work.

For example, if the low beam headlights work, but the high beams and the indicator lamp don't work, then power and ground paths must be good. Since the dimmer switch is the component that switches this power to the high beam lights and indicator, it is most likely the cause of failure.

2-5 HOW TO USE THIS MANUAL

2001 F53

TROUBLESHOOTING WIRING HARNESS AND CONNECTOR HIDDEN CONCERNS

The following illustrations are known examples of wiring harness, splices and connectors that will create intermittent electrical concerns. The concerns are hidden and can only be discovered by a physical evaluation as shown in each illustration.

NOTE: Several components, such as the PCM, utilize gold plated terminals in their connections to the wiring harness. If those terminals need to be replaced, they must be replaced with a gold plated terminal.

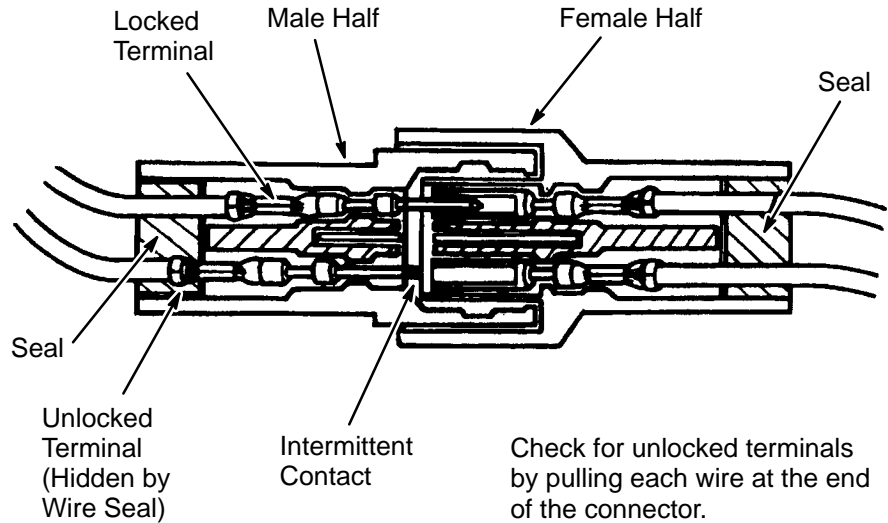

TERMINAL NOT PROPERLY SEATED

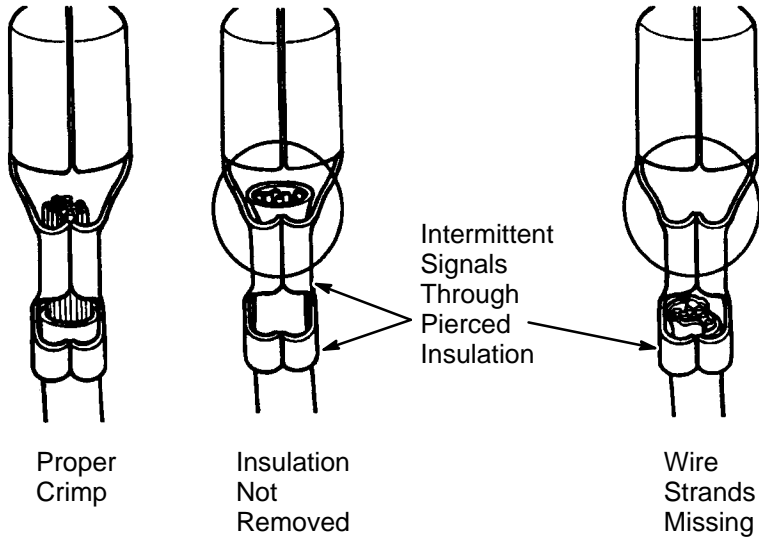

DEFECTIVE INSULATION STRIPPING

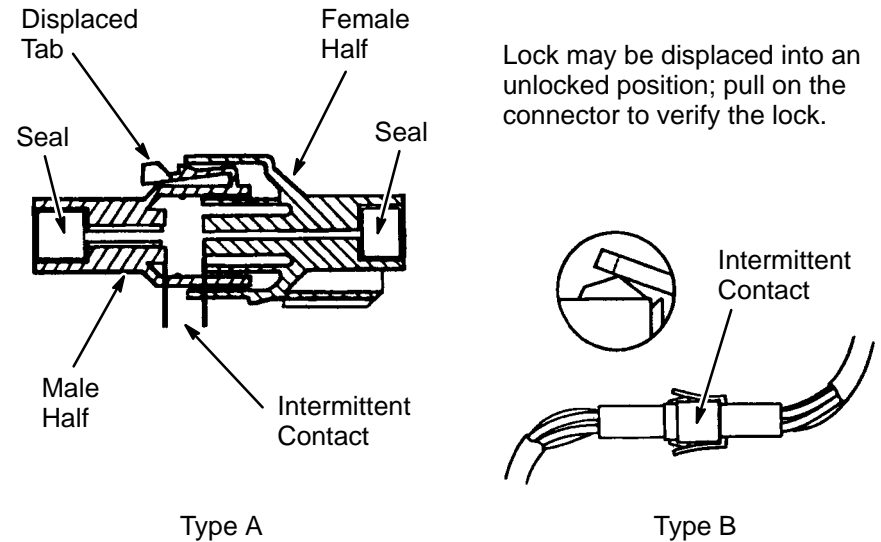

PARTIALLY MATED CONNECTORS

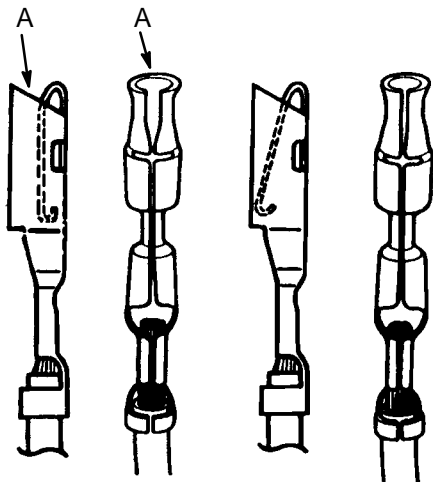

Enlarged

Normal

Any probe entering the terminal may enlarge the contact spring opening creating an intermittent signal. Insert the correct mating terminal (Location A) from the service kit and feel for a loose fit.

DEFORMED (ENLARGED) FEMALE TERMINALS

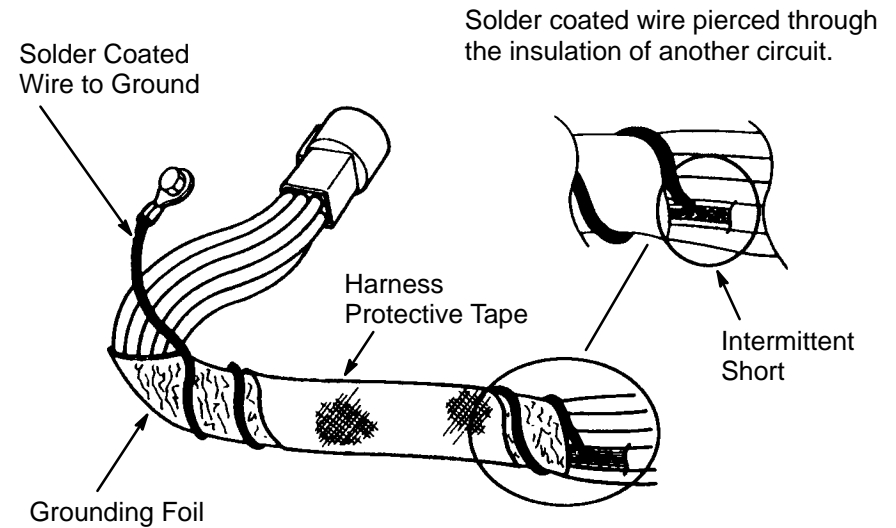

ELECTRICAL SHORT INSIDE THE HARNESS

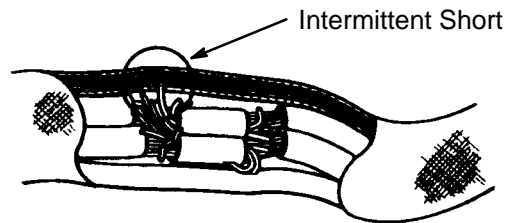

Splice Tape Removed

Operate the system and flex the harness at splice location noted in Section 152.

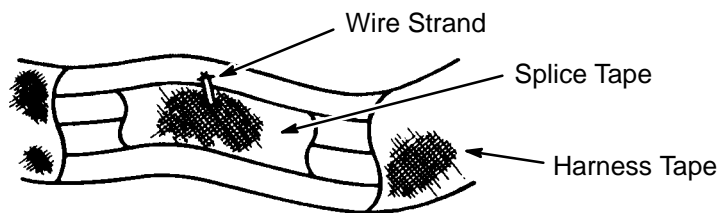

Splice Covered

ELECTRICAL SHORT WITHIN THE HARNESS

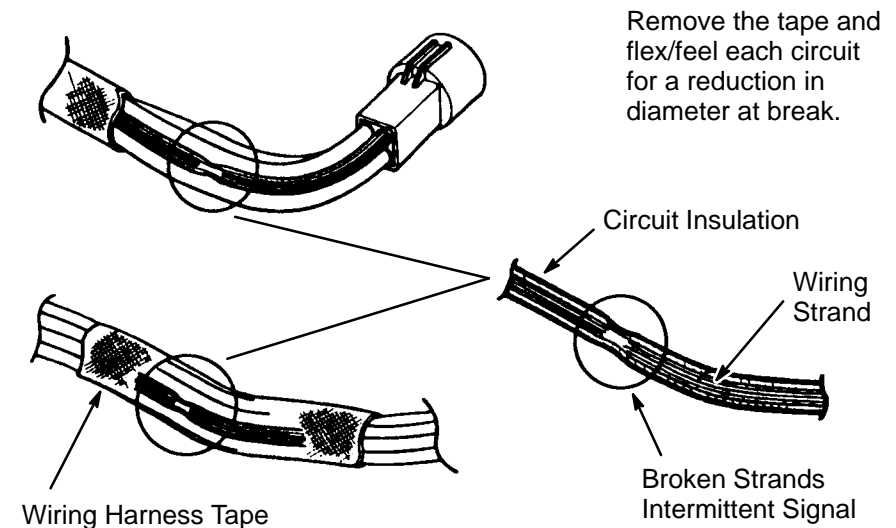

BROKEN WIRE STRANDS IN HARNESS

2-7 HOW TO USE THIS MANUAL

2001 F53

RECOMMENDED SPLICING METHOD:

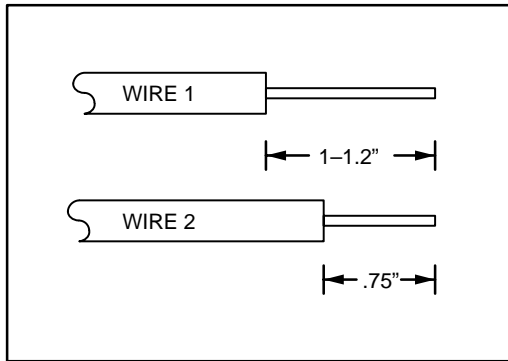

1. Disconnect battery ground cable.
2. Strip wires to appropriate length.

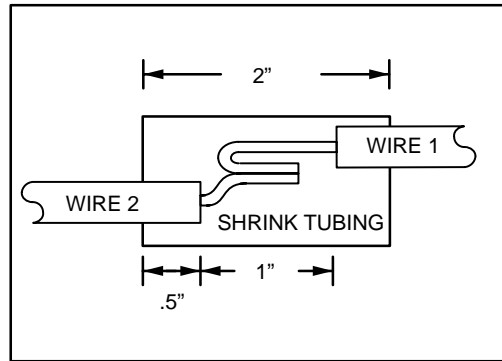

7. Evenly position heat shrink tubing over wire repair.
NOTE: Overlap tubing on both wires.

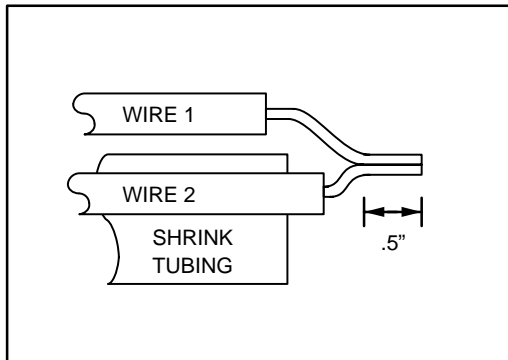

3. Install heat shrink tubing.
4. Twist wires together.
5. Solder wires together.
NOTE: Use rosin core mildly-activated (RMA) solder. Do not use acid core solder.

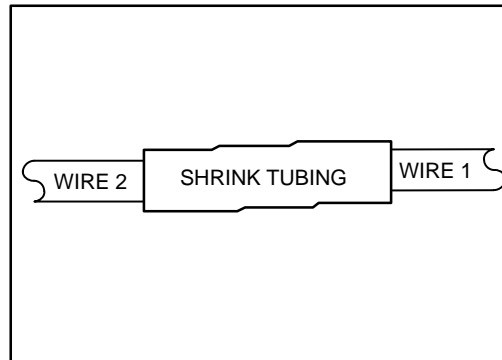

8. Use heat gun to heat the repaired area until adhesive flows out of both ends of heat shrink tubing.
9. Reconnect battery ground cable.

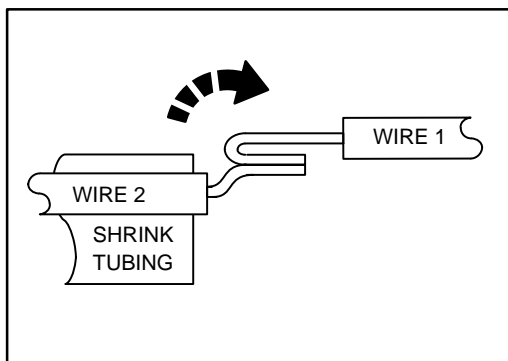

6. Bend Wire 1 back in a straight line.
NOTE: Wait for solder to cool before moving wires.

ELECTRICAL SYMBOLS



DASHED COMPONENT BOX
ONLY PART OF THE COMPONENT IS SHOWN ON THE PAGE; THE COMPONENT IS SHOWN COMPLETE IN ANOTHER LOCATION

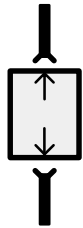

COMPONENT WITH CONNECTORS



BATTERY

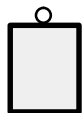

SCREW TERMINAL ON COMPONENT

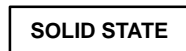

SEALED ELECTRONIC COMPONENT ANY CIRCUITRY SHOWN INSIDE THE BOX IS A FUNCTIONAL EQUIVALENT ONLY AND IS NOT EXACT



GROUND CONNECTION

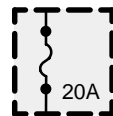

FUSE
CURRENT RATING

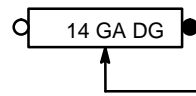

FUSIBLE LINK
WIRE SIZE AND COLOR

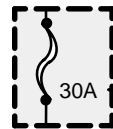

MAXI-FUSE or FUSIBLE LINK CARTRIDGE
CURRENT RATING

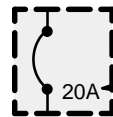

CIRCUIT BREAKER
CURRENT RATING

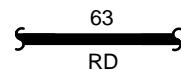

SOLID WIRES

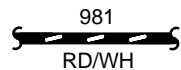

STRIPED WIRES

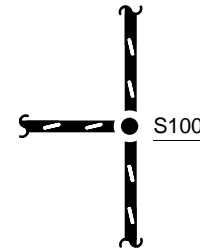

SPLICE OR CRIMP TERMINAL

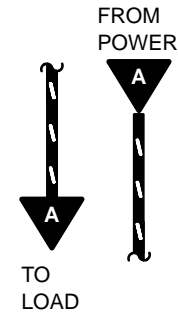

"CUT" WIRES REFERENCED BETWEEN PAGES ARROWS SHOW CURRENT FLOW FROM POWER TO GROUND



REVERSING LAMPS

"REFERENCE" WIRES COMPLETE WIRING SHOWN ON ANOTHER PAGE

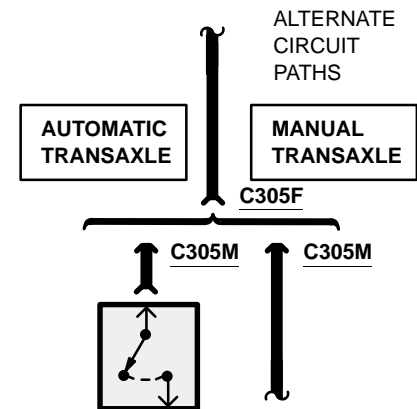

2-9 HOW TO USE THIS MANUAL

2001 F53

ELECTRICAL SYMBOLS

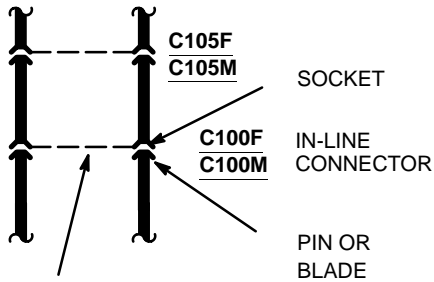

SINGLE DASHED LINE INDICATES THAT WIRE ON LEFT ALSO PASSES THROUGH THE SAME CONNECTOR

SEE GROUNDS
PAGES 10-1,
10-2

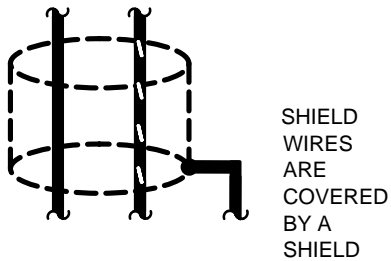
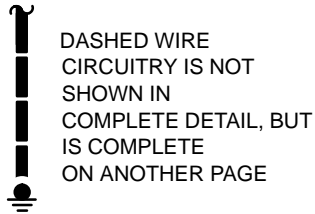

MOTOR



HEATING ELEMENT



THERMISTOR



RHEOSTAT OR POTENTIOMETER



SOLENOID

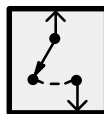

SWITCH

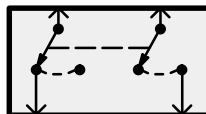

GANGED SWITCHES CONTACTS MOVE AT THE SAME TIME



DIODES CURRENT FLOWS IN DIRECTION OF ARROW ONLY

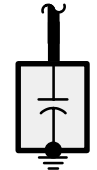

CAPACITOR



TRANSISTOR

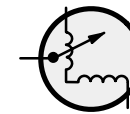

GAUGE



LIGHT EMITTING DIODE (LED)



LIGHT BULB

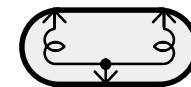

DUAL FILAMENT LIGHT BULB

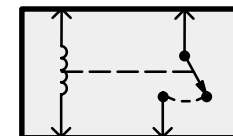

RELAY CONTACTS CHANGE POSITION WITH CURRENT THROUGH COIL

